

WHEN DISASSEMBLING ALUMINUM EXTRUSION, TIGHTEN ALL SETSCREWS AND LOCKS TO PREVENT LOSS DURING SHIPPING

visionary™ DESIGNS

Using Your Setup Instructions

The Visionary Designs Setup Instructions are created specifically for your configuration. They are laid out sequentially, including an exploded view of the entire display, and then a logical series of detailed steps to assemble the main structure and components. We encourage you to study the instructions **before** attempting to assemble your exhibit.

Each page reminds you to tighten the setscrews after disassembling your exhibit to prevent loss of the locks and setscrews (see below in RED). This is **VERY IMPORTANT**.

Cleaning and Packing Your Display

- 1) Use care when cleaning aluminum extrusion or acrylic inserts. Use only non-abrasive cleaners.
- 2) When cleaning laminate inserts or countertops, use mild cleansers and a soft material such as cotton.
- 3) Keep all display components away from extreme heat and long exposure to sunlight to avoid warping and fading.
- 4) Retain all packing material. It will make re-packing much easier and will reduce the likelihood of shipping damage.



The Tool

Most Visionary Designs exhibits can be assembled with the supplied Hex Key Tool. Occasionally, a flat head screwdriver may be required.



Typical Connection

Most horizontal extrusion connections have a patented expandable lock. This lock inserts into the groove of an opposing extrusion. Tightening the lock with the Hex Key Tool expands the lock and creates a strong positive connection.



Typical Connection (cont'd)

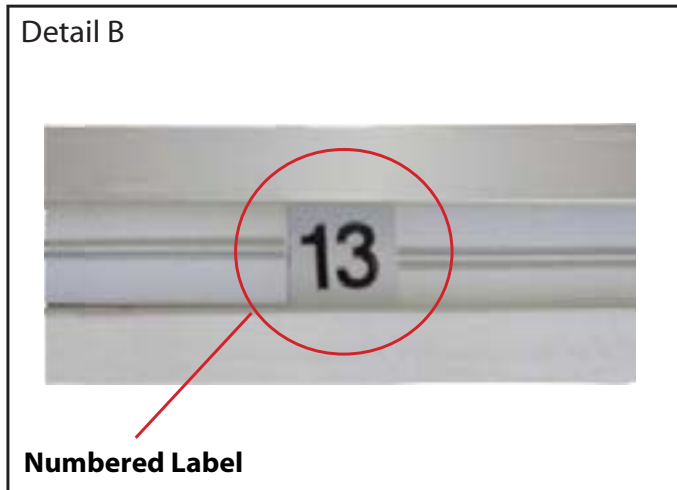

Detail B

Numbered Label

Each extrusion contains a numbered label which corresponds with setup instructions. The label is located within a groove of the extrusion (when possible). With Visionary Designs the labels contain Black numbers unless otherwise specified.



Detail C

Horizontal Inline Connection (remove only one setscrew)

Remove only (1) setscrew when disassembling. Replace setscrew in extrusion after assembling it. Before packing, replace setscrew in extrusion to avoid losing it.

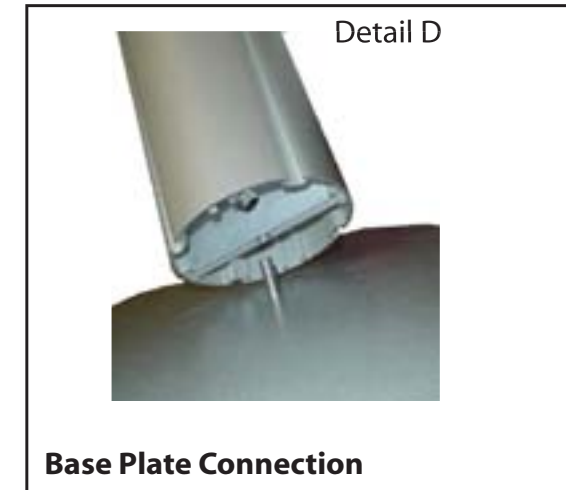

Detail D

Base Plate Connection

Attach base plate to round or square vertical extrusion using the bolt provided. Be careful not to strip the threads.

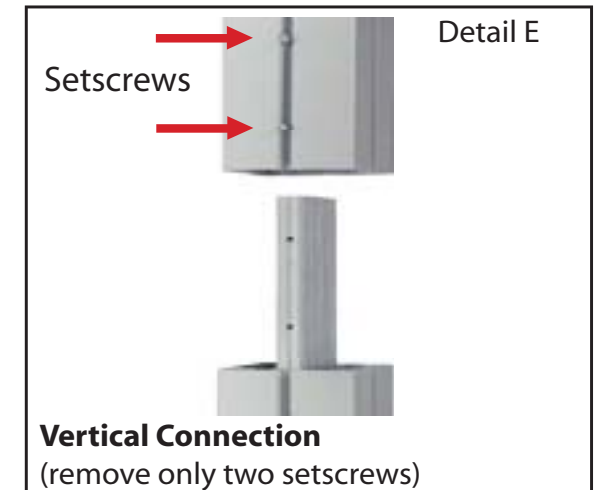

Detail E

Vertical Connection
(remove only two setscrews)

When vertical extrusions are packed in portable cases rather than crates or tubs, they must be broken down into smaller sections which then require assembly.

Remove only (2) setscrews when disassembling. Replace setscrews in extrusion after assembling it. Before packing, replace setscrews in extrusion to avoid losing them.

WHEN DISASSEMBLING ALUMINUM EXTRUSION, TIGHTEN ALL SETSCREWS AND LOCKS TO PREVENT LOSS DURING SHIPPING

Item	Quantity	Description
1	2	Oval Base Plate
2/2a	1	47.5"h Round Vertical Extrusion
3/3a	1	47.5"h Round Vertical Extrusion
4/4a	1	47.5"h Round Vertical Extrusion
5/5a	1	47.5"h Round Vertical Extrusion
6a/6b	1/1	50.875" Curved Horizontal Extrusion
7a/7b	1/1	50.875" Curved Horizontal Extrusion
8a/8b	1/1	50.875" Curved Horizontal Extrusion

Steps:

- 1) Connect vertical extrusions [3 and 5] to lower vertical extrusions [2 and 4].
- 2) Connect vertical assemblies [2/3 and 4/5] to oval base plates [1], refer to Detail D on General Info. Page.
- 3) Assemble curved horizontals by connecting pieces [6a to 6b, 7a to 7b, 8a to 8b].
- 4) Connect lower curved assembly [6a/6b] between vertical assemblies [4/5 and 2/3] as shown below.
- 5) Connect curved assemblies [7a/7b] between vertical assemblies [4/5 and 2/3].
- 7) Connect curved assemblies [8a/8b] between vertical assemblies [4/5 and 2/3].

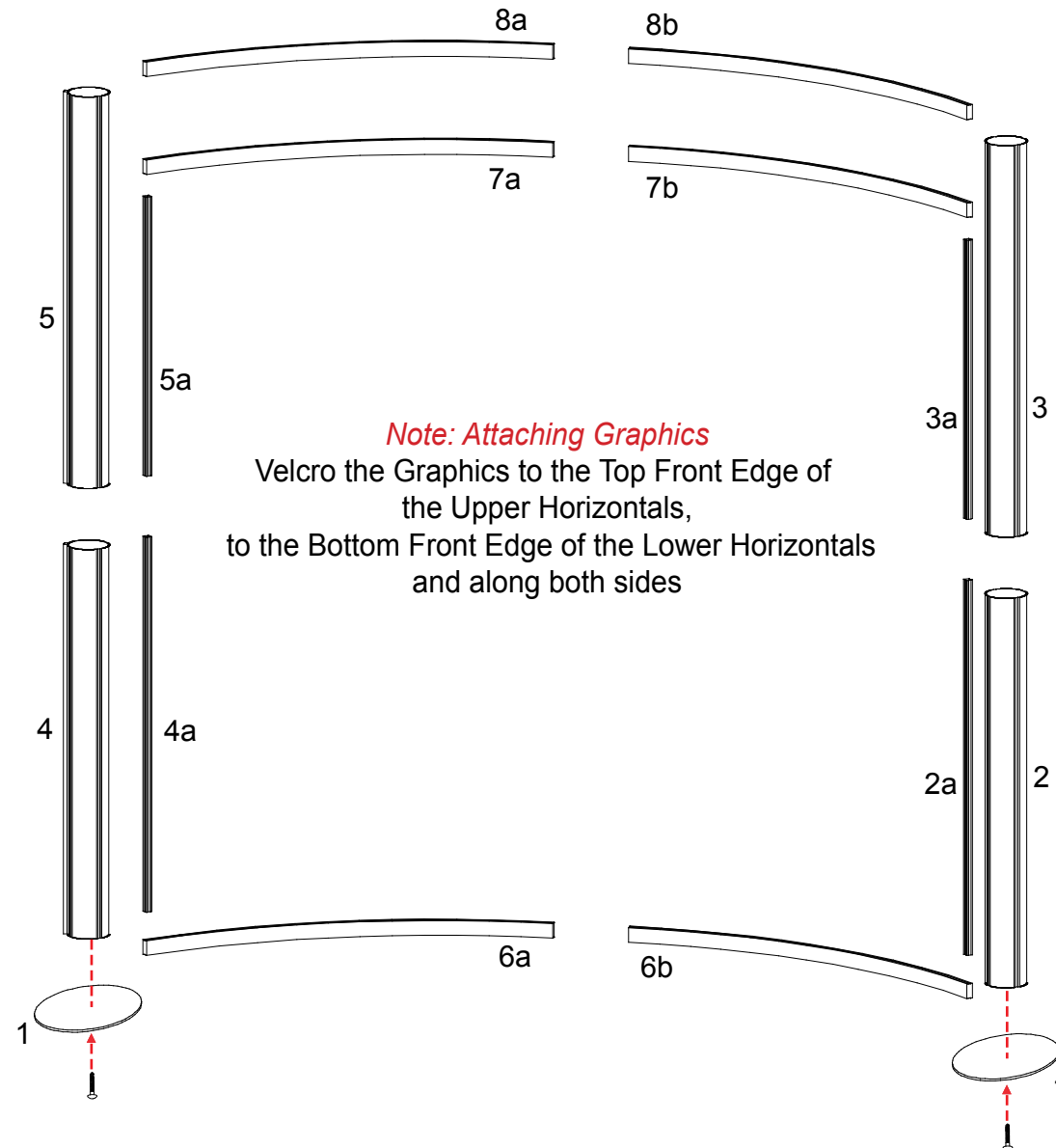

WHEN DISASSEMBLING ALUMINUM EXTRUSION, TIGHTEN ALL SETSCREWS AND LOCKS TO PREVENT LOSS DURING SHIPPING

866.652.2100

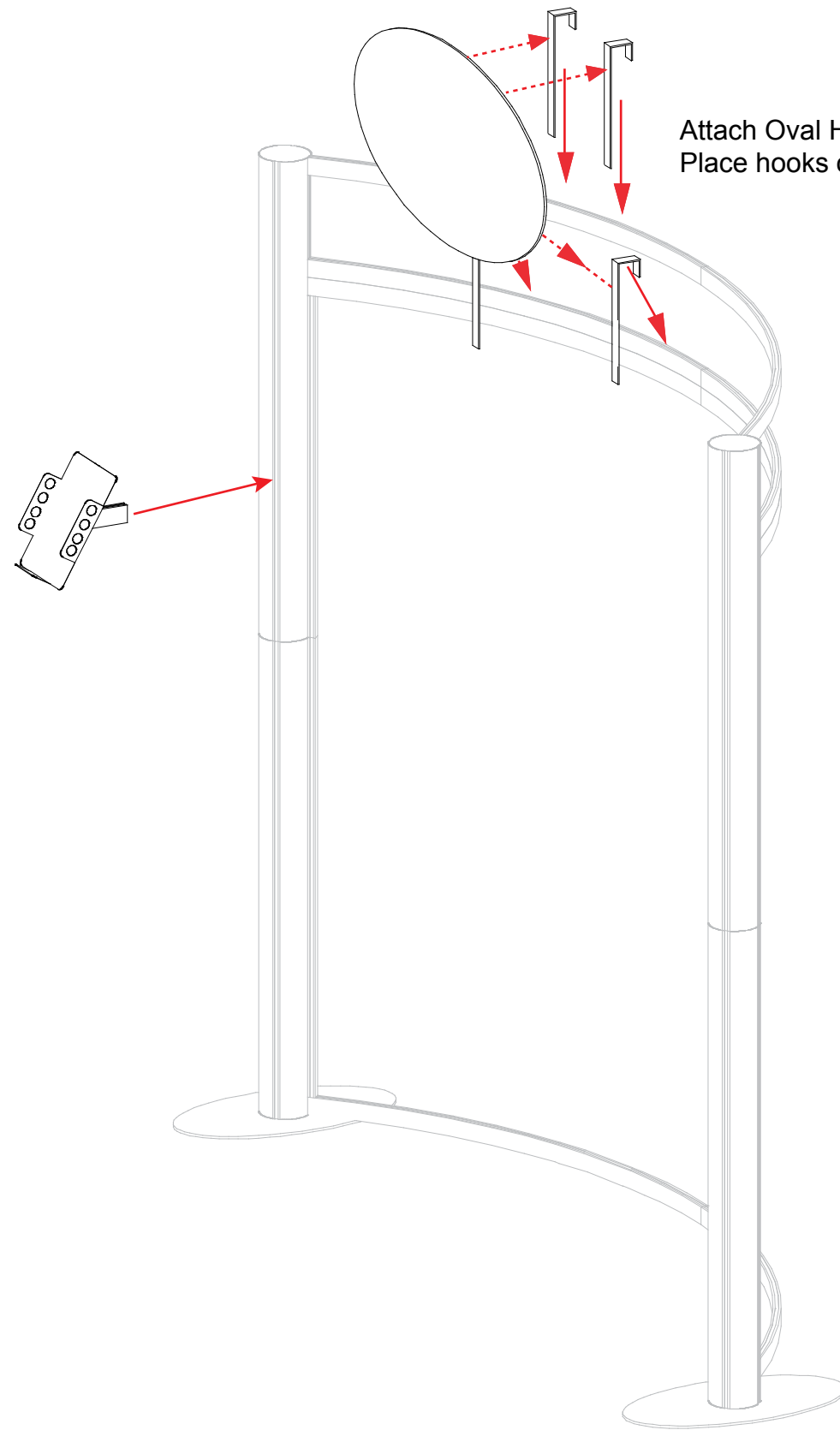

Attach Oval Header to Hooks with Velcro, 1 on top center and 1 on bottom center. Place hooks over backwall as shown.

Literature Rack Attachment

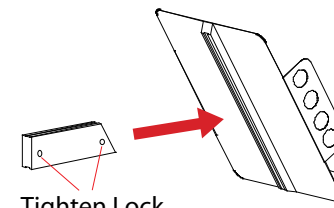

Tighten Lock to Secure

Attach connector piece to rack as shown. Then connect assembled literature rack to connector extrusion.

WHEN DISASSEMBLING ALUMINUM EXTRUSION, TIGHTEN ALL SETSCREWS AND LOCKS TO PREVENT LOSS DURING SHIPPING

866.652.2100

Item	Quantity	Description
15	1	38" h Vertical Extrusion
16	1	38" h Vertical Extrusion
17	1	42" h Vertical Extrusion
17A	1	Plate for Counter Connection
18	1	38" h Vertical Extrusion
19	2	20" w Horizontal Extrusion
20	2	8.5" w Horizontal Extrusion
21	2	20" w Horizontal Extrusion
22	2	8.5" w Horizontal Extrusion

Steps:

- 1) Connect horizontal extrusions [19 and 20] between vertical extrusions [15, 16, 17 and 18] at approximately 3.5" up from floor to bottom of metal.
- 2) Set floor in place atop lip of horizontal extrusions.
- 3) Place doors and inserts in place as shown.
- 4) Connect horizontal extrusions [21 and 22] between vertical extrusions [15, 16, 17 and 18] and atop inserts and door.
- 5) Velcro shelf supports to inside of pedestal, then set internal shelf atop supports.
- 6) Place counter atop assembled pedestal, attach [17A] to extrusion [17] then connect smaller counter to [17A].

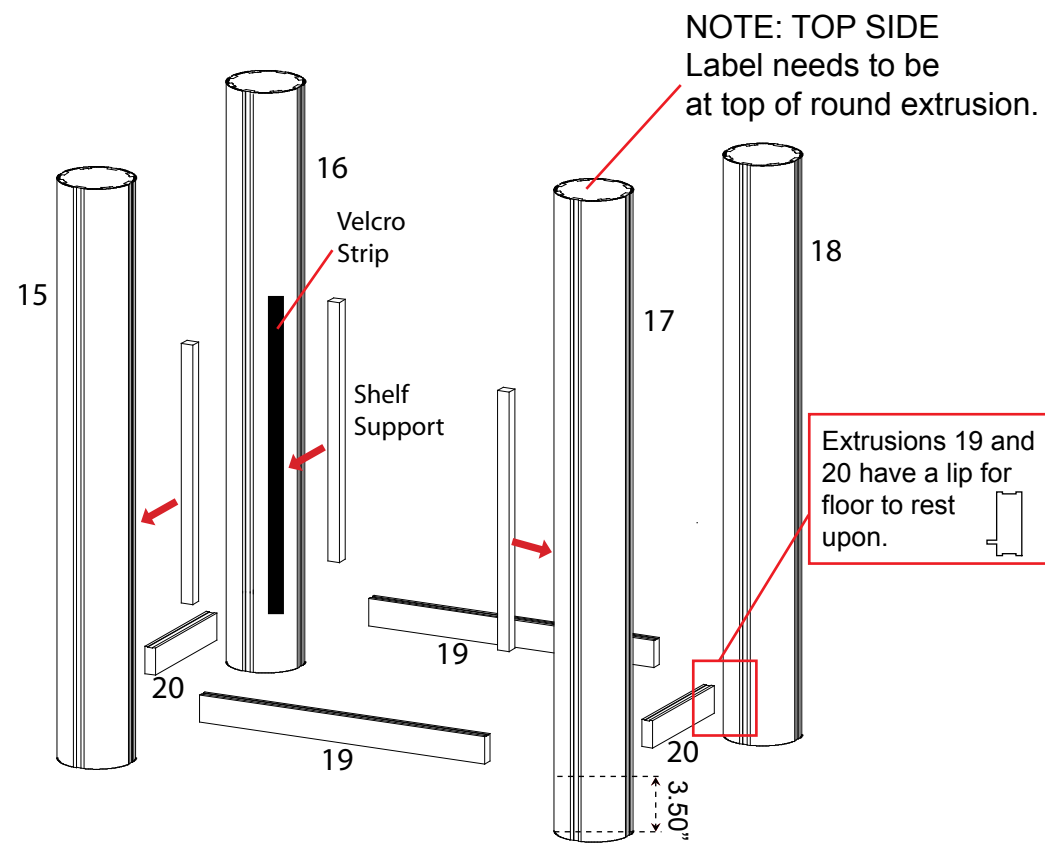
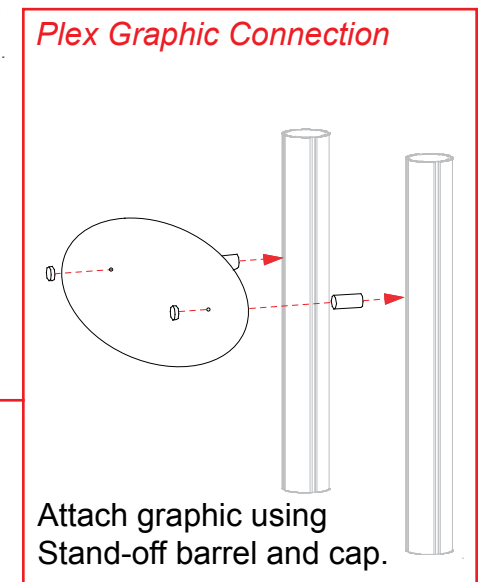
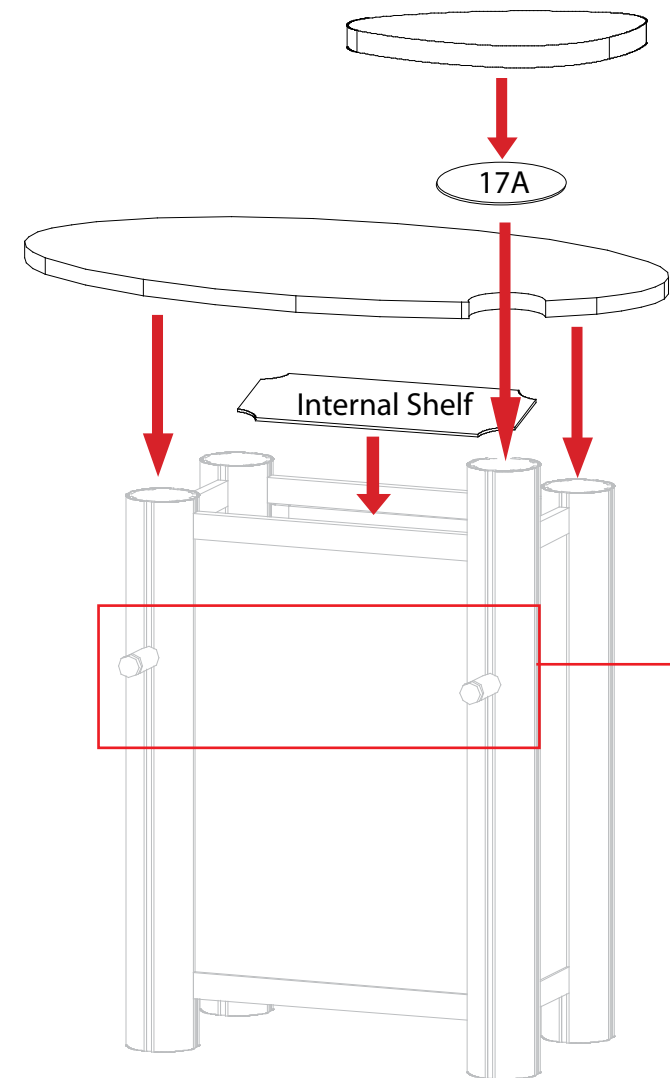
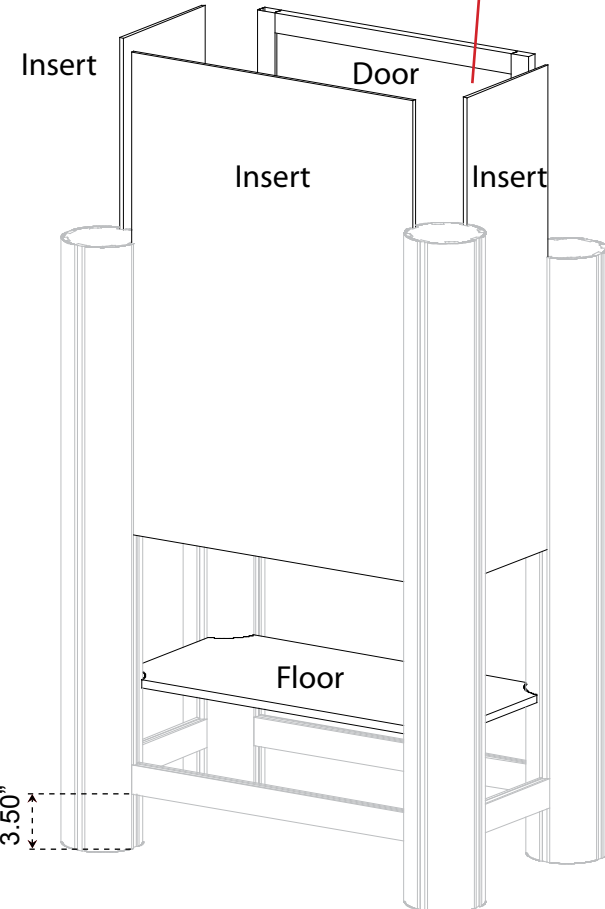
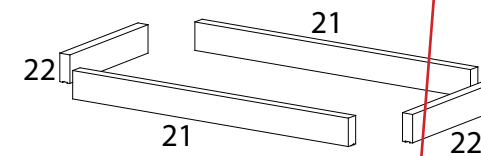
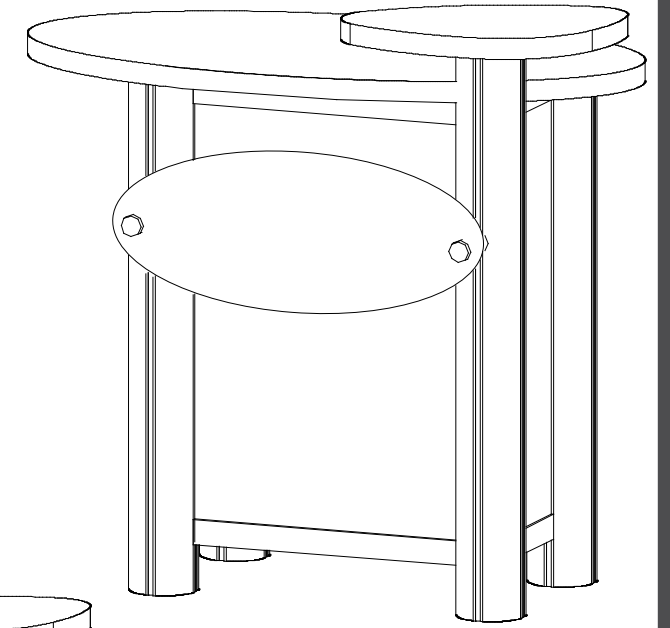
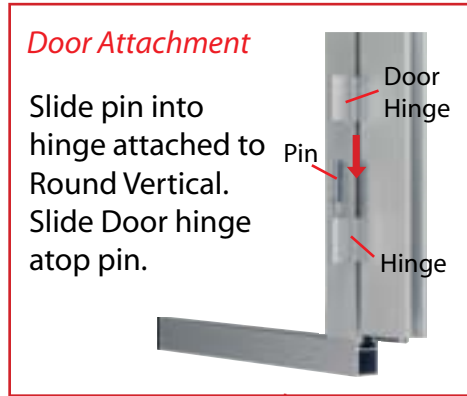

WHEN DISASSEMBLING ALUMINUM EXTRUSION, TIGHTEN ALL SETSCREWS AND LOCKS TO PREVENT LOSS DURING SHIPPING